

PAX 654 Specifications

- **Unique Double-Edge profile and corner radii.** Sink lies completely flat on worktop and cloths will not snag on corners
- **2 x 90mm Waste with Basket Strainer Waste.** Capable of adaptation to take Waste Disposal Unit
- **Accessories colour-keyed in White, Blue or Black**
- **Available as a Designer Value Pack**

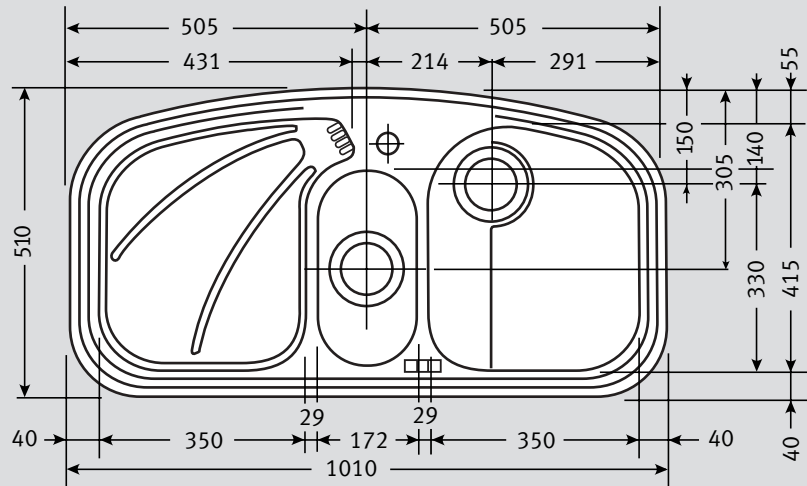

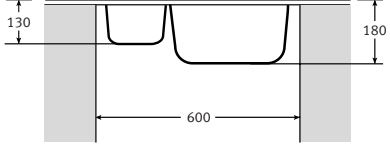

Material:	304 Austenitic 18/10 Stainless Steel
Application:	Inset or undermount
Bowl size:	350 x 415 x 180 } Bowls welded to frame 175 x 330 x 130 }
Drainer Format:	Left or right hand drainer available
Cut-out size:	980 x 490 (utilise template)
Colour:	Silk Stainless Steel
Seal:	Factory Fitted Polyurethane Seal
Heat Resistance:	Up to 300°C
Insulation:	Grey Dynaphon for heat and sound
Earthing Point:	Utilise clip boss
Cabinet size:	

Waste: 1 x Lira 90mm Basket Strainer Waste with overflow
1 x Lira 90mm Basket Strainer Waste

Overflow:

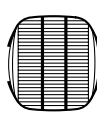
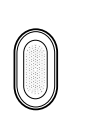
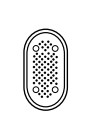

Accessories available:

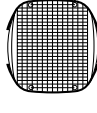
 Food Preparation Platter Hygena. Colour keyed White, Blue, Black	 Drainer Tray Stainless Steel Colour keyed White, Blue, Black	 Strainer Bowl Available in White, Blue or Black	 Strainer Bowl Stainless Steel
 Grater Stainless Steel Colour keyed White, Blue, Black	 Drainer Basket Stainless Steel Colour keyed White, Blue, Black		

Sink Profile: Double Edge

Fixing Clips:

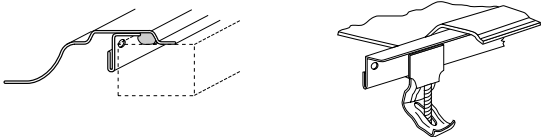

Suggested Plumbing Kit: 2 part

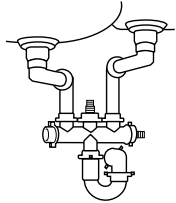

Taps: Any Franke tap can be utilised with this model*.

*Ceramic disc taps in certain installations or where there is a low head of water (below 4 metres) may not provide adequate flow rates. You are advised to check with your supplier.

Some taps may need bracing to avoid flexing of the sink ledge.

Guarantee: Franke sinks are guaranteed for 25 years against manufacturing defect. Franke taps are guaranteed against defective materials and workmanship for 1 year in relation to coatings and finishes, and 5 years in relation to moving parts. Franke will replace (and where appropriate repair) defective sinks. In relation to taps, Franke will where appropriate provide replacement parts for your taps or replace your taps. Any associated or ancillary costs to be incurred by you as a result of replacement of Franke sinks and taps under this guarantee shall in all cases be previously approved by Franke UK Limited.
This guarantee is in addition to and does not affect your statutory rights.

The Franke policy is one of continued improvement, and Franke reserve the right to alter models and specifications without notice.